

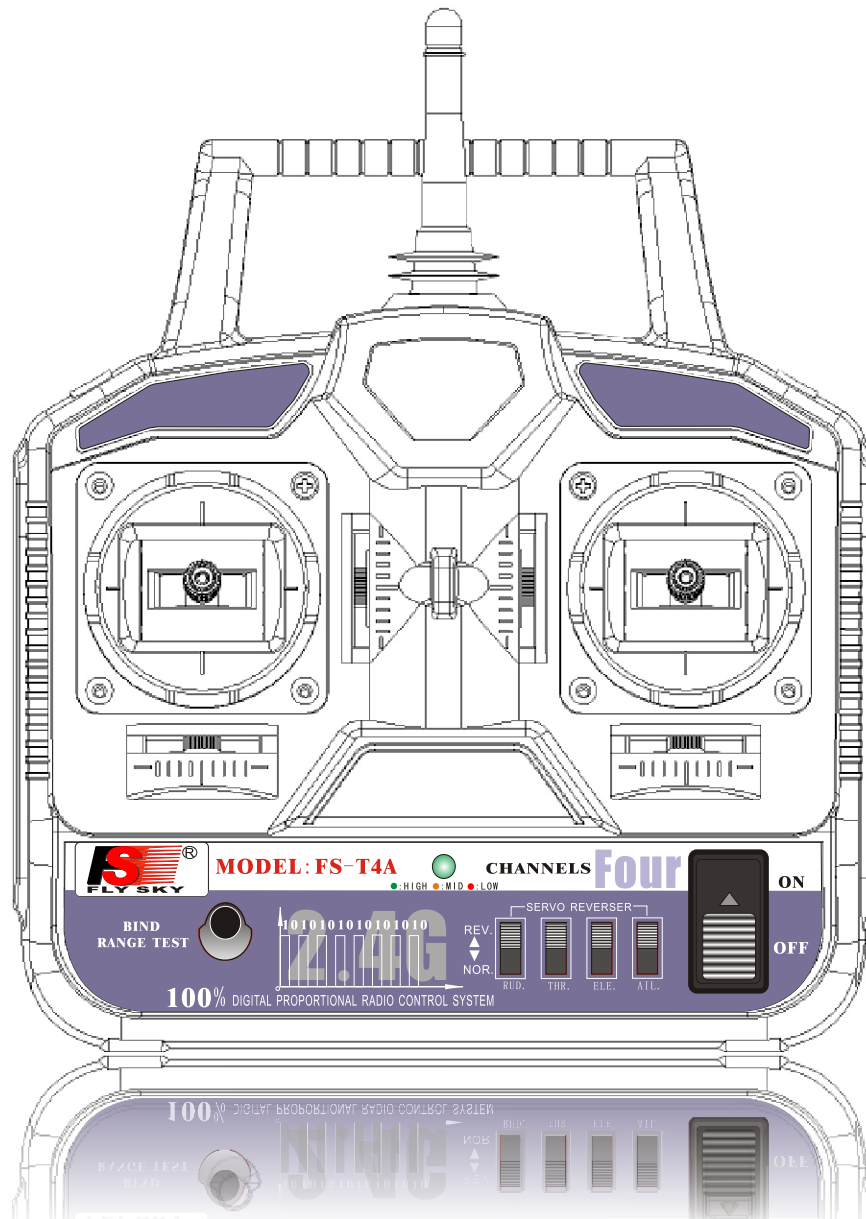

# 4 CHANNEL RADIO CONTROL SYSTEM

# INSTRUCTION MANUAL



**MODEL:FS-T4A**

Digital propotional radio control system

[Http:www.flyskychina.com](http://www.flyskychina.com)  
Copy right 2007@flysky co. , ltd

# Menu

1. Introduction. . . . .	2
2. Services. . . . .	2
3. The special symbols. . . . .	3
4. safty guides. . . . .	3
5. Power charging. . . . .	4
6. Transmitter parameters. . . . .	5
7. Receiver parameters. . . . .	5
8. Each part of the transmitter. . . . .	6
9. Receiver and server connectivity. . . . .	7
10. 2. 4G Operation Notes. . . . .	8
10. 01 Matching. . . . .	8
10. 02 Boot. . . . .	8
10. 03 Shutdown. . . . .	9
11. Functional Description. . . . .	10
11. 01. 1Channel function description. . . . .	10
11. 02. 3Channel function description. . . . .	10
11. 03. 2Channel function description. . . . .	11
11. 04. 4Channel function description. . . . .	11
12 Professional terminology. . . . .	12
13 Packaging with content list. . . . .	13

## 1.Introduction

Thank you for choosing 2.4 G ratio remote control digital products, if you are the first time to use this type of products, please read this statement carefully and strictly in accordance with the requirements of operation. You could refer to the Manual if you meet any problems during the operation. Please well keep the manual after use because you might have to use it again next time. Once again, thanks for buying our products, and hope that it brings happiness to you.

## 2.Services

If you found any problems during the operation process, please refer to the manual. If the problem still exist, you could contact our dealers to found out the way to solve. And you could also log on to our website service center:

**HTTP: WWW. FLYSKYCHINA. COM**

### 3.The special symbols

Please pay attention to the following symbols when it appear on the manual, and read carefully.

 **Danger:** If the operator does not operate by following the instructions, the operator may lead to serious injuries, even Mortal danger.

 **Warning:** If the operator does not operate by following the instructions, the operator may lead to serious injuries, even Mortal danger.

 **Attention:** If the operator does not operate by following the instructions, the operator may lead to minor injuries, but generally it will not cause serious injuries to the operator.



**Prohibition**



**Mandatory**

### 4.Safy guides



Do not fly in bad weather such as rainy or thundering to assure the safety of you and others.



Before you fly, please make sure the movement of server are correspond with the direction of joystick. If inconsistent, please adjust before fly.



You need to turn the throttle channel(ch3) and inching switch to the lowest before you use. Then switch on the transmitter power (red light or flashing means low battery),finally connect the receiver.



The Sequence to shut down is first turn the receiver power and the transmitter power.

If the above operations are reverse, it might lead to uncontrolled and cause accident.

## 5. Battery charging notes



If your transmitter, receiver using a nickel-cadmium, nickel-metal hydride rechargeable battery, you have to well-check before you fly. If lack of electricity, it could happen those phenomenon like inadequate control or out of control, resulting accident. So please charge immediately when low in battery.



If you are using a nickel-cadmium, nickel-metal hydride batteries for recharging, please use our company dedicated charger. If the electrical current is too large and it may lead to temperature over-heated and cause fire burning accident. Please cut off the power supply immediately after recharging. Please take out the battery from the transmitter when you are not using it within a period, it is because the battery may damage the aircraft batteries, thus being exposed.

### Transmitter charger:

1. Install the battery to transmitter with correct direction, and cover it.
2. Connect the charger to the main connector.
3. Connect the charger to the transmitter Connector.
4. Cut off the power supply immediately after Recharge completed.

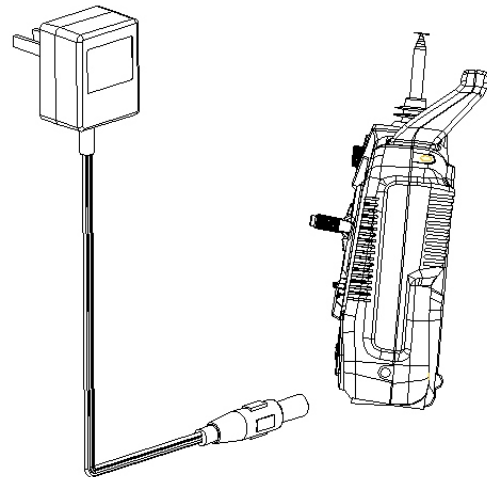

### Receiver charger:

1. Connect the charger to the main connector.
2. Connect the Rechargeable receiver with battery charger
3. Recharge completed, cut off the power supply immediately.

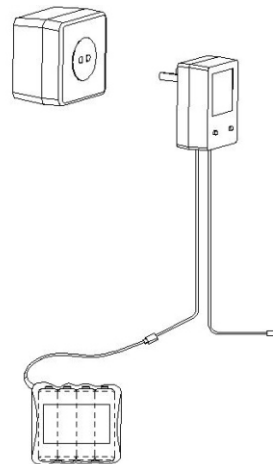

## 6. Transmitter parameters

- \*Channels: 4
- \*Charger port: yes
- \*Frequency band: 2.4GHz
- \*Simulator port: PS-2
- \*Power resource: 1.5V\*8 "AA"Battery
- \*Program type: GFSK
- \*Modulation type:FM
- \*RF power: 19db
- \*Static current:  $\leq 250\text{mA}$
- \*Voltage display type: LED
- \*Size: 189\*97\*218mm
- \*Weigth: 575g
- \*Color: black
- \*Antenna length: 26mm

## 7. Receiver parameters

- \*Channel: 6
- \*Frequency band: 2.4GHz
- \*Power resource: 1.5V\*4 "AA"Battery
- \*Program type: GFSK
- \*Modulation type: FM
- \*RF Receiver sensitivity: -76db
- \*Static current:  $\leq 85\text{mA}$
- \*Size: 45\*23\*13.5mm
- \*Module Size: 25\*16.8\*6.5mm
- \*Weigth: 12g
- \*Color: Gary semi-transparent
- \*Antenna length: 26mm

2. 4G 4 Channel remote system

8. Each part of the transmitter

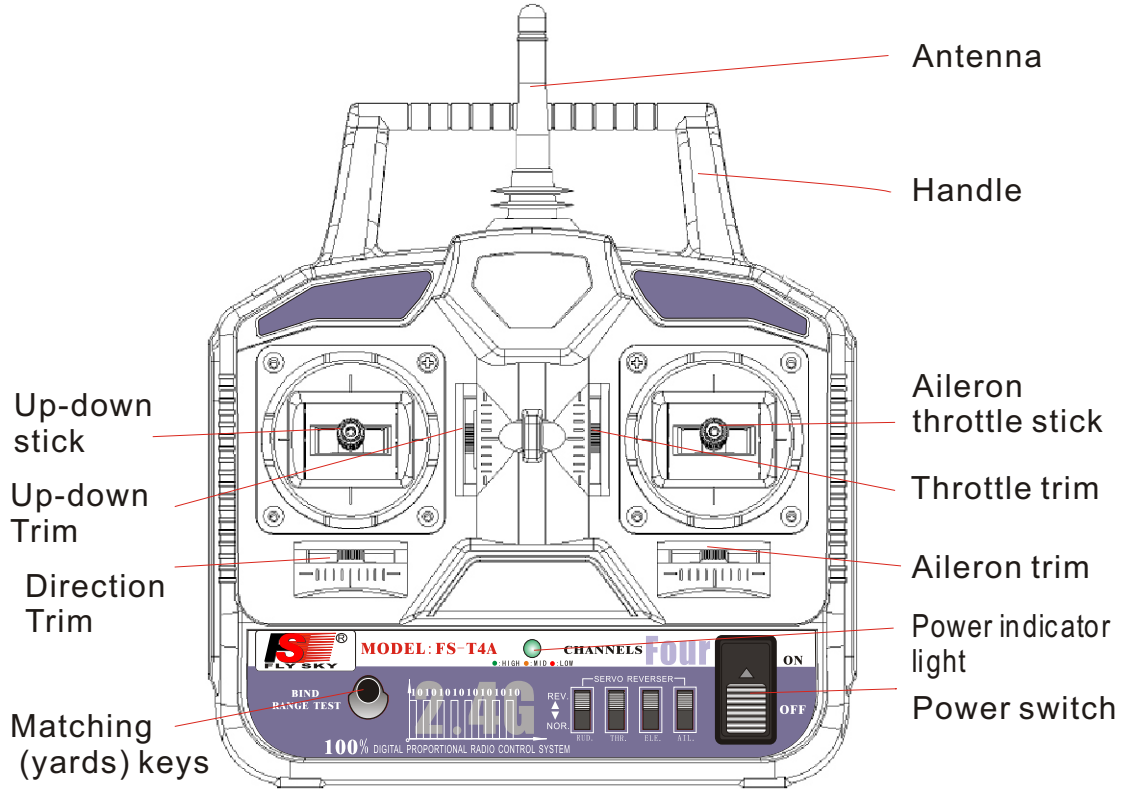

Front

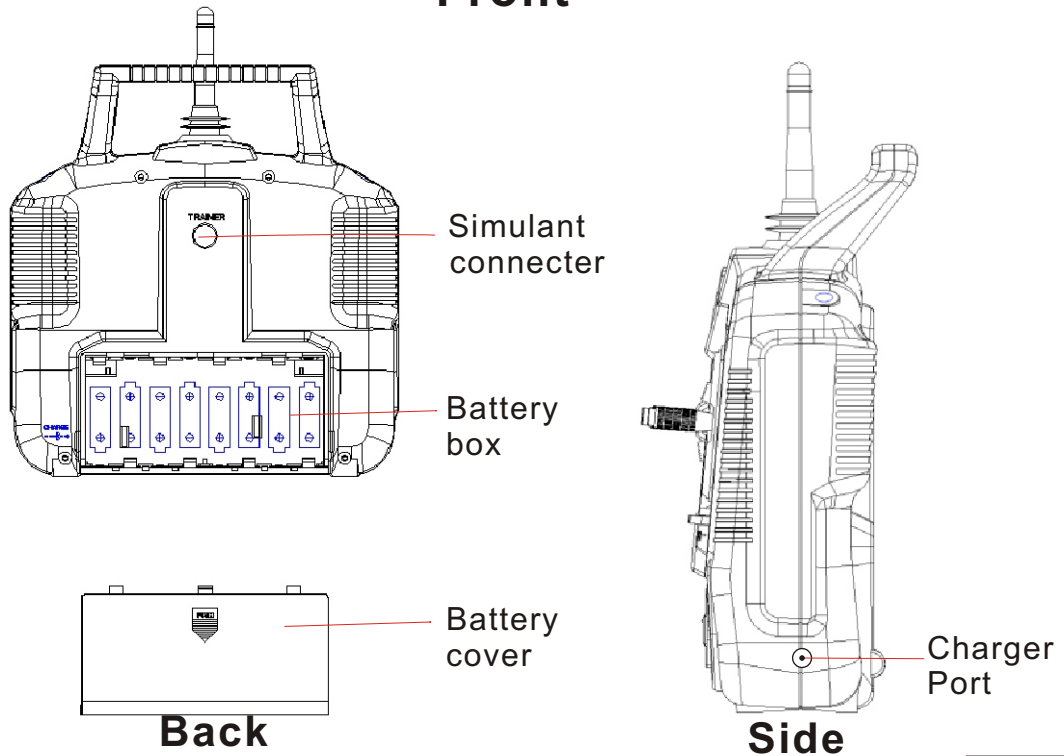

Back

Side

## 9.Receiver and server connectivity

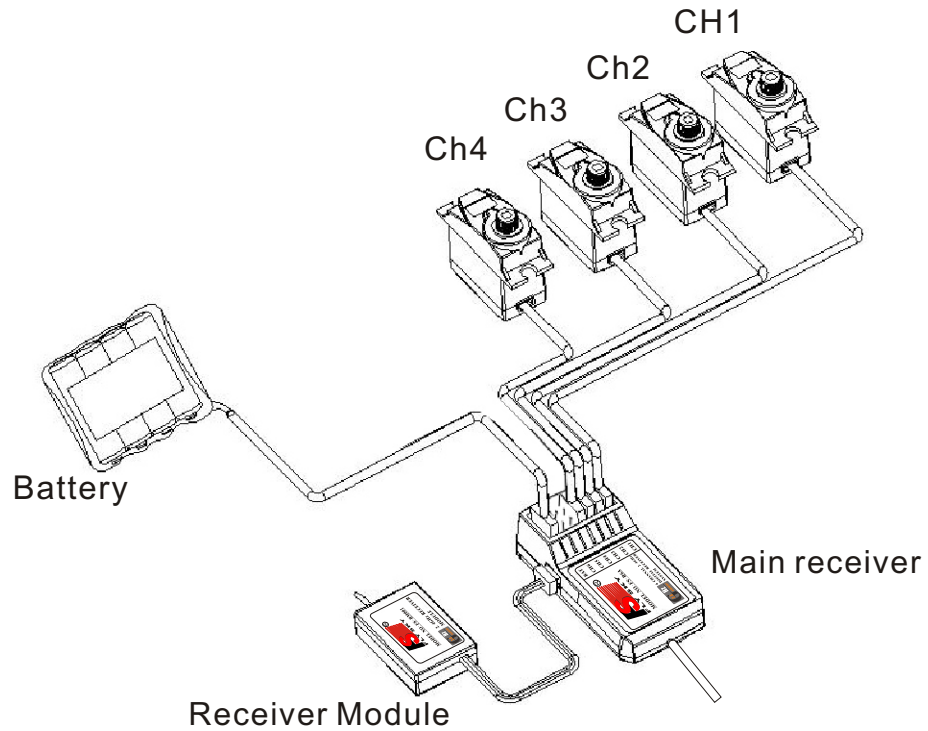

When installing the receiver please make sure that two items showed 90 degree angle.

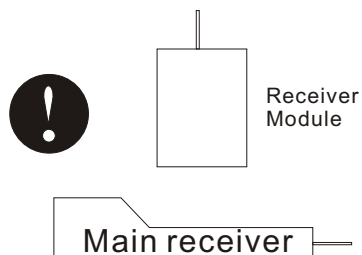



## 10. 2. 4G Operation notes

This is 2.4 G Frequency model products make of automatic address code. It use digital transmission mode, and this prevent outside interference effective active and passive.

### 10. 01 Matching (code)

Our products are well matched in the factory, you do not need to match by yourself. But if your are going to match the receiver with other transmitter, please follow the following steps:

1. Install the battery to 2.4G transmitter and shut it down.
2. Insert the matching lines to the channel Bat port of the receiver. (Figure.1) 。
3. Connect the receiver battery to any one of the channel port, on the same time the two LED are flashing and this means the receiver are going to the match status.
4. Press and hold the button on the transmitter, and then switch on the power supply.
5. Observe the LED on the receiver, if found that the LED is not flash anymore and that means successful matched. (This process about 10s)
6. Release the match button on the transmitter, take out the match line.
7. Install the server and then test.
8. If the tests fail, please repeat the action above.
9. If the tests success, then insert the power supply port into BAT, match complete. (The above ways of match is only suitable on FLYSKY 2.4G products)

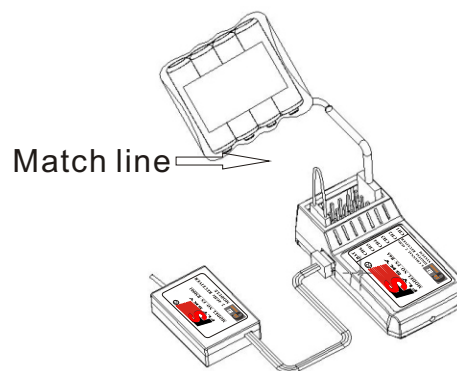
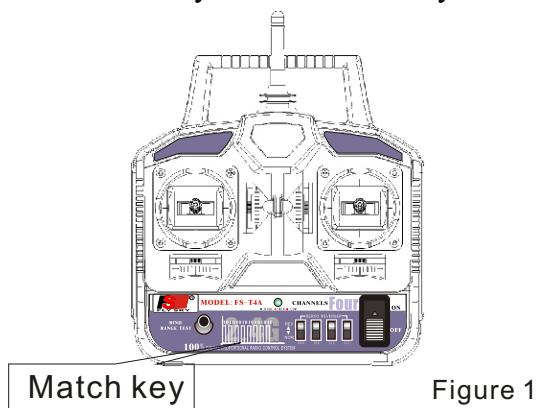

### 10. 02 Boot

1. Connect every part.
2. Switch on the power supply.
3. Connect the power supply.
4. Receive LED light solid.
5. Finish and use.

2. 4G 4 Channel remote system

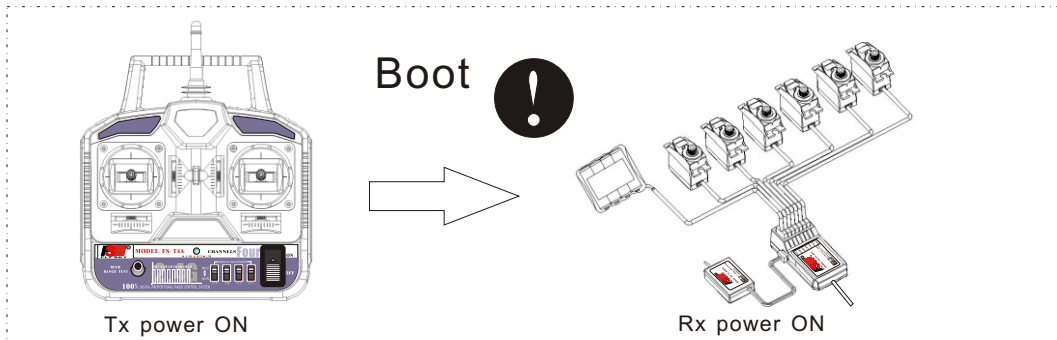

10. 03 Shut down:

1. Cut off the receiver power supply.
2. Cut off the transmitter power supply.

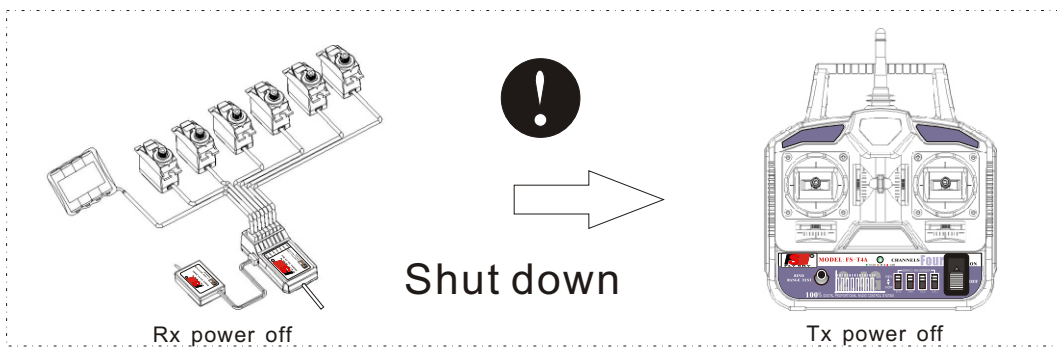

## 11.Functional description

### 11. 01. 1 Channel control

This channel is for aileron control .

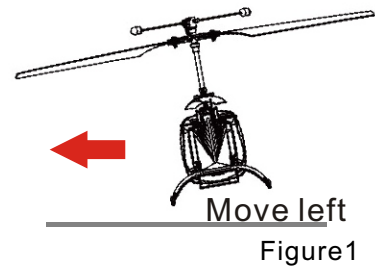
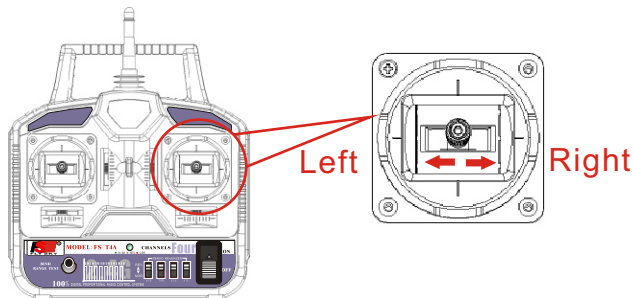

If you move the transmitter stick to the left, The airplane will inclined to the left and the airplane move left. (Figure.1)

If you move the transmitter stick to the right, the airplane will inclined to the right and the airplane move right. (Figure.2)

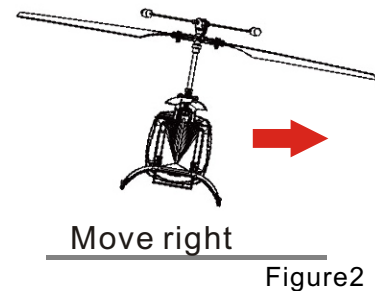

### 11. 02. 3 Channel control

This channel is use for throttlecontrol.

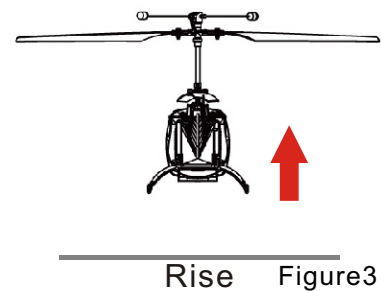
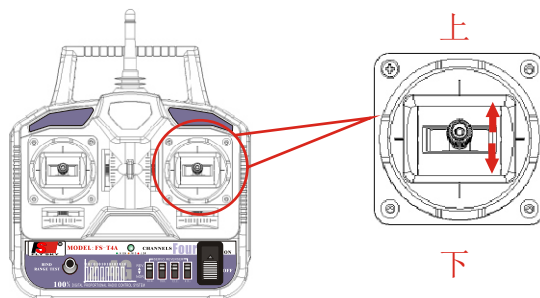

If you move the transmitter stick upward the power of airplane will increase and the airplane rise. (Figure.3)

If you move the transmitter stick downward the power of airplane will decrease and the airplane drop. (Figure.4)

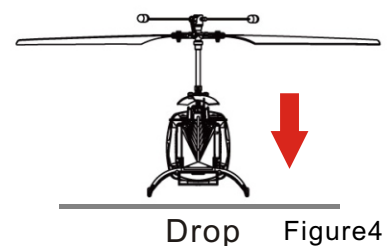

11. 03. 2 Channel control

This channel is use for forward and backward control.

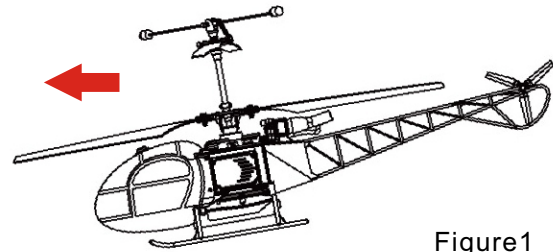
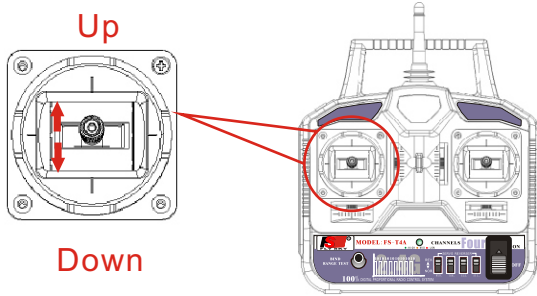

Move forward

If you move the transmitter stick upward, the airplane will move forward. (Figure.1)。

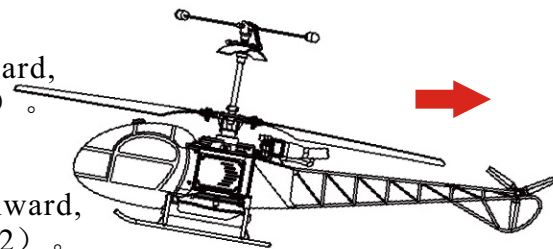

Move backward

If you move the transmitter stick downward, the airplane will move backward. (Figure.2)。

11. 04. 4 Channel control

This channel is use for left and right turning control.

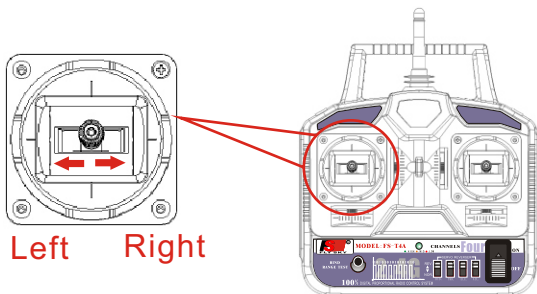

If you move the transmitter stick to the left, The airplane will turning to the left. (Figure.3)

If you move the transmitter stick to the right, The airplane will turning to the right. (Figure.4)

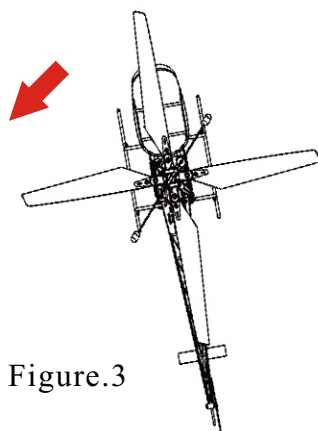

Left turning

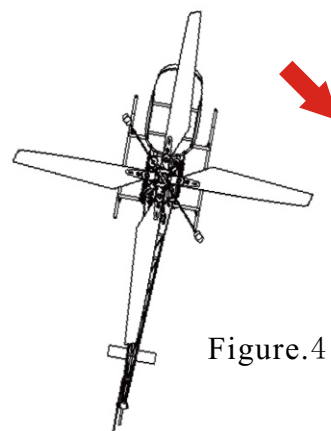

Right turning

## 12. Professional terminology

AIL:副翼  
ELE:升降舵  
THR:油门  
RUD:方向舵  
GEAR:  
PITCH:螺距  
FM:调频  
PPM:脉冲相位编码  
PCM:脉冲数据编码  
MODULE:调制  
RF:射频  
DR:双重比率  
TRAINER:教练  
STICK:操纵杆  
NULL:无功能  
REV:反向  
NOR:一般  
TRIM:微调  
SUB. TRIM:辅助微调  
HELI:直升机  
ACRO:飞机  
VR:电位器  
SW:开关  
UP:上  
DOWN:下  
DES:目标  
SOURCE:起源  
IDEL:特技

### 13.Packaging with content list

NO :	Model	Sum	Remarks
1	4 channel 2. 4G transmitter (FS-T4A)	1	
2	6 channel 2. 4G receiver (FS-R6A)	1	
3	Match(code)line	1	
6	Charger	1	Optional
7	Server (FS-S036)	4	Optional
8	Manual (FS-T4A)	1	



---

**Http: [www.flyskychina.com](http://www.flyskychina.com)**  
**Copy right 2007@flysky co. , ltd**